

LEGACY



Owners Manual For The  
**Phantom**  
Loudspeaker System

---

# Table of Contents

Registration	Page
Owners Record	3
The Cabinetry / Our Commitment	4
Setup	
Unpacking Your Speakers	5
Speaker Installation	6-9
Hooking Up Cables	10-12
Amplification	13-15
Technology	
Specifications	16

---

# Owners Record

The serial number is located on the rear of the unit. Record this number in the space provided below. Refer to this when calling your dealer regarding this product.

Model: Phantom

Serial No: \_\_\_\_\_

Date of purchase: \_\_\_\_\_

Thank you for selecting a Legacy Loudspeaker System. These hand-crafted instruments will provide you with many years of listening enjoyment.

---

# The Cabinetry / Our Commitment

## **Handcrafted**

Beneath the surface of Phantom's elegant exterior lies rigid MDF construction. Interlocking joinery maximizes the strength of the cabinet parts. Polyester fiberfill is selected for internal damping. A sharp rap on the enclosure will leave you with little more than bruised knuckles.

Each cabinet is impeccably finished on all exposed surfaces with select veneers. The exquisite finish is hand-rubbed several times to assure a patina at home with the most elegant decor.

## **Our Commitment**

A great deal of forethought, love and satisfaction is instilled in each piece of Legacy workmanship. We take pride in getting to know many of our customers on a first name basis.

Your purchase of this product is backed by the renowned "Legacy Satisfaction Guarantee".



---

# Unpacking Your Speakers

Your new speaker system has been very carefully packaged to insure that it travels to you safely. Each speaker is protected by a double-wall outer carton with heavy V-board corner protectors. Molded foam end caps are used to protect the elegant cabinetry, and a plastic liner is provided as waterproofing. Please save this packing for future transportation. If cartons become damaged or misplaced, new ones can be purchased from Legacy Audio.

---

# Speaker Installation

## **Precautions**

If you have any doubts about your ability to properly install on-wall loudspeakers, you should consider the services of a custom installer. If you plan to install them yourself, always use high quality tools to save time and make the installation go more smoothly. The Phantom On-Wall Loudspeakers mount on standard 16-in center stud walls. Determine the final location of both left and right speakers before drilling any holes since changes to one speaker may affect the other either aesthetically or acoustically. Look for pipes, wiring or any other conflicting material that might be damaged before beginning the installation.

---

# Speaker Installation

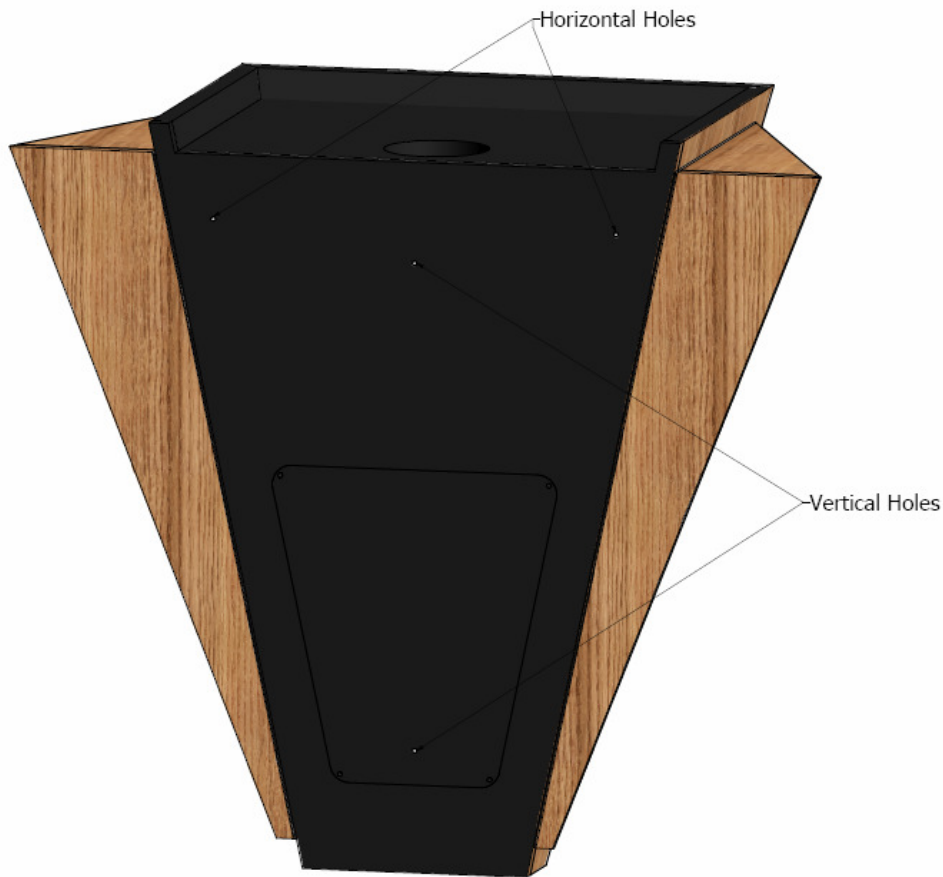

Figure 1

- There are two options when mounting the Phantom Loudspeaker. The bracket can be mounted either vertically on one stud or horizontally on two 16-inch center studs.
- Place the provided screws in the appropriate holes based on how you wish to mount your speakers. Please see figure 1.

---

# Speaker Installation

## Vertical Mounting

- Find the center of one stud and mount the provided bracket using the provided screws. Place screws in the holes highlighted in red in figure 2.
- Lift the cabinet and slide the screws on the back of the cabinet into the keyholes. This may take two people to accomplish this task.

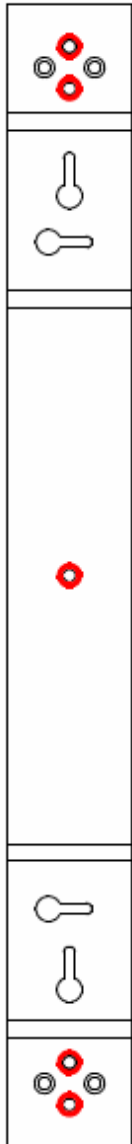

Figure 2

---

# Speaker Installation

## Horizontal Mounting

- Find the center of the two studs and mount the provided bracket using the provided screws. Place screws in the holes highlighted in red in figure 3.
- Lift the cabinet and place the screws on the back of the cabinet into the keyholes. Slide the cabinet to lock it into place. This may take two people to accomplish this task.

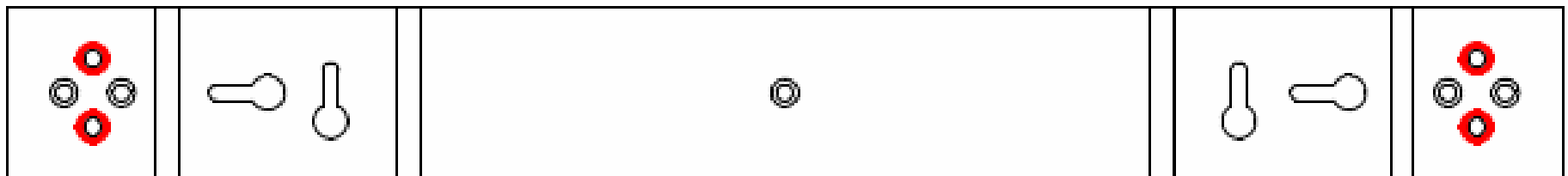

Figure 3

---

## Hooking Up Cables

Before you purchase loudspeaker wire, check local building codes to make sure that the wire is rated to comply with applicable local safety codes such as UL or CL-2. Use only stranded wire no thinner than AWG 16. For runs longer than 100 feet, we recommend minimum of AWG 14. When pulling wire, take care not to pull the wire too fast to prevent stretching the wire or scorching the insulation from friction. Leave 2 to 3 feet of excess loudspeaker wire at both ends; it is easier to trim off excess wire than to splice additional wire. When securing the wire inside the walls, be careful not to pierce the insulation with nails or staples.

---

# Hooking Up Cables

The ideal conductor would have negligible resistance, inductance and capacitance. The table below shows how a few actual speaker cables measure up.

Cable	$\Omega$ s/ft	pF/ft	$\mu$ H/ft
12 ga.	0.0033	24	0.21
14 ga.	0.0048	17	0.13
16 ga.	0.0079	16	0.18
18 ga.	0.0128	28	0.21



Capacitance is considered insignificant in each cable because its effect is well out of the audio bandwidth; inductance can be decreased (at the expense of increased capacitance) by keeping the conductor pair closely spaced.

How long would a cable have to be before inductance effects would impinge on the audio spectrum? Approximately 300 feet of 12 gauge would be required to establish a corner frequency of 20 kHz with an 8 Ohm loudspeaker. As you see, inductance is not a problem for most of us.

---

# Hooking Up Cables

What about phase shift due to frequency dependent travel times down the speaker cable? Measurements show that 100 Hz waves will be delayed about 20 billionths of a second behind 10 kHz waves when traveling to the end of a 10 foot speaker cable. Since the cilia of the ear requires 25,000 times longer than this just to transmit phase information, phase shifting is obviously not the primary concern when considering speaker cables.

What about resistance? Finally we are getting somewhere. Resistance is the controlling factor of the amplifier/loudspeaker interface. Excessive resistance can cause major shifts of speaker crossover frequencies. The lower the impedance of the loudspeaker, the greater the effects of series resistance. A 20 foot run of 18 gauge cable can cause up to 10% deviations of crossover center frequencies. That same 20 feet can un-damp your damping factor and reduce your systems' output by onehalf decibel.

In summary, there are no perfect cables. The best way to approximate the ideal would be to keep loudspeaker leads as short as is practical.

---

# Amplification

Ideally the loudspeaker would be among the first components selected when assembling a playback system. This would allow the user to choose an amplifier capable of delivering adequate amounts of current into the frequency dependent load presented by the loudspeaker. However, when upgrading a system, audiophiles may find themselves matching their new loudspeakers to their existing amplification. For this reason, extensive measures have been taken to ensure that each Legacy speaker system represents a smooth, non-reactive load to virtually any amplifier.

Often there is much confusion regarding amplification and loudness levels. It should be understood that the role of the amplifier goes beyond that of driving loudspeakers to a given sound pressure level. The amplifier should be able to CONTROL the loudspeakers across the entire music spectrum. This means that parameters such as damping factor (values greater than 60 are acceptable) and dynamic headroom should not be overlooked when comparing amplifiers.



---

# Amplification

How much power will your new speakers need? That ultimately depends on your listening environment and musical tastes. As little as five watts per channel should drive them to a level satisfactory for background music. A typical 45 watt per channel receiver may fill a room with the compressed mid-band energy of "heavy metal," but seem to lack weight or control with classical recordings. Some audiophiles feel that 200 watts per channel is the bare minimum to avoid audible clipping distortion when reproducing music at "live" playback levels. Your Legacy speakers are designed to take advantage of "high-powered" amplifiers, so don't be afraid to put them through their paces.

How much is too much power? Rarely is a drive unit damaged by large doses of music power. More often than not the villain is amplifier clipping distortion. Even through decades of refinement, loudspeakers are still notoriously inefficient transducers, requiring huge amounts of power to recreate the impact of the live performance. Typically less than 1% of electrical power is converted into acoustic output. (For example, an omnidirectional transducer with an anechoic sensitivity of 90 dB @ 1w/1m has a full space efficiency of only 0.63%)

---

# Amplification

When an amplifier is unable to fulfill your loudspeakers demands, a damaging harmonic spike may be leaked to the high frequency drivers.



Another important point regarding loudness is that the dB scale is a logarithmic one. This means that a 150 Watt amplifier will potentially sound only twice as loud as a 15 Watt amplifier. If all of this discussion of power and loudness seems a bit abstract, consider the example below.

*The average acoustical power developed by a person speaking in a conversational tone corresponds to a mere 0.00001 Watts. The power that would be developed by the entire population of the city of New York speaking at once would barely illuminate a single 100 Watt light bulb.*

---

# Specifications

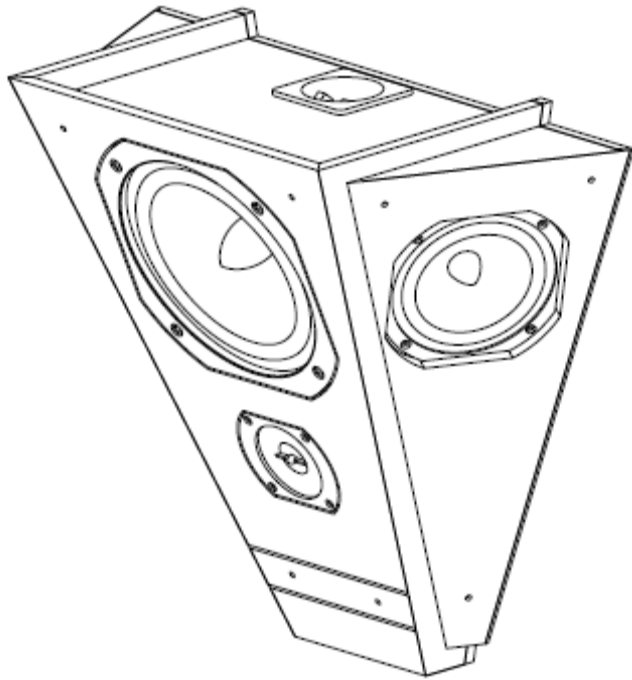

<b>System Type:</b>	4 drivers, 3 way
<b>Tweeter:</b>	1" Titanium Diaphragm W/ Neodymium Motor
<b>Midwoofer:</b>	2 x 5.25" Silver Graphite
<b>Woofers:</b>	1 x 8" Silver Graphite
<b>Low Frequency Alignment:</b>	Boundary Compensated, M-S Array
<b>Frequency Response:</b>	50Hz – 25 kHz
<b>Impedance:</b>	4 Ohms
<b>Sensitivity:</b>	93 dB
<b>Recommended Amplification:</b>	25-200 Watts
<b>Crossover Frequency:</b>	200, 3K
<b>Dimensions (H x W x D):</b>	21" X 9" X 19"
<b>Weight:</b>	48 pounds

Notes:



©2008 Legacy Audio  
3023 E Sangamon Ave.  
Springfield, IL 62702  
Phone: 800-283-4644  
Fax: 217-544-1483