

JS-TA224 9' TONEARM

USER' S MANUAL

Important Precautions ---



- Be sure to adjust the tracking force to less than 2.0g before setting the cartridge, to avoid damaging the stylus!



- When installing the tonearm, please handle it gently to avoid breaking the arm wire!

CONTENTS

Important Precautions	2
Introduction	4
The brief of Jasmine Audio	
The design concept of Jasmine Audio	
Installation	5
Unpacking	
Packing list	
Arm base installation	
Connection of tonearm cable	
Install a cartridge	
JS-TA224 Specification	9
Warranty	10

Introduction

Thank you for purchasing Jasmine JS-TA224 9-inch arm. Your choice is a correct decision, we sincerely believe that it will bring you many years of music happiness and satisfaction. Most users are eager to install and listen to the new device after receiving it. However, we hope you can take a few minutes to read this manual and familiarize yourself with the installation and precautions of jasmine JS-TA224. In order to protect your warranty rights and reduce the risk of damage to the arm, please read the important notes on page 2 of this manual. Also, pay special attention to the fields with an exclamation mark on the left.

The Brief of Jasmine Audio

Jasmine audio was founded in China in 2001 by several domestic and foreign audiophiles who deeply love HIFI culture. In the early stage, it was specially manufactured for other HIFI brands. Since 2008, we have independently designed and produced products with Jasmine brand.

Jasmine has won many awards both in China and abroad due to its high reputation in the international market.

Jasmine design and produce HIFI level audio products. It is our unswerving goal to bring wonderful music enjoyment to users.

The design concept of Jasmine Audio

Pure, simple and natural !

Installation

This section describes how to install the Jasmine JS-TA224 tonearm

Unpacking



After you receive the Jasmine JS-TA224 tonearm, please open the box to check whether the product appearance has obvious deformation and damage. If yes, please do not install the product, contact your seller or agent in time to inform the problems and ask for the after-sales service.

Please do not rush to throw away the package of the product. We suggest that you keep it for at least one month, In order to avoid the unnecessary disputes due to the lack of the original package when you applying for after-sales service.

Packing List

There should be:

- 1 * Counterweight
- 1 * Tonearm body
- 1 * SME2D20-H10-S tonearm mounting base
- 1 * JS-TA224 protractor
- 1 * Tonearm cable
- 1 * User's manual

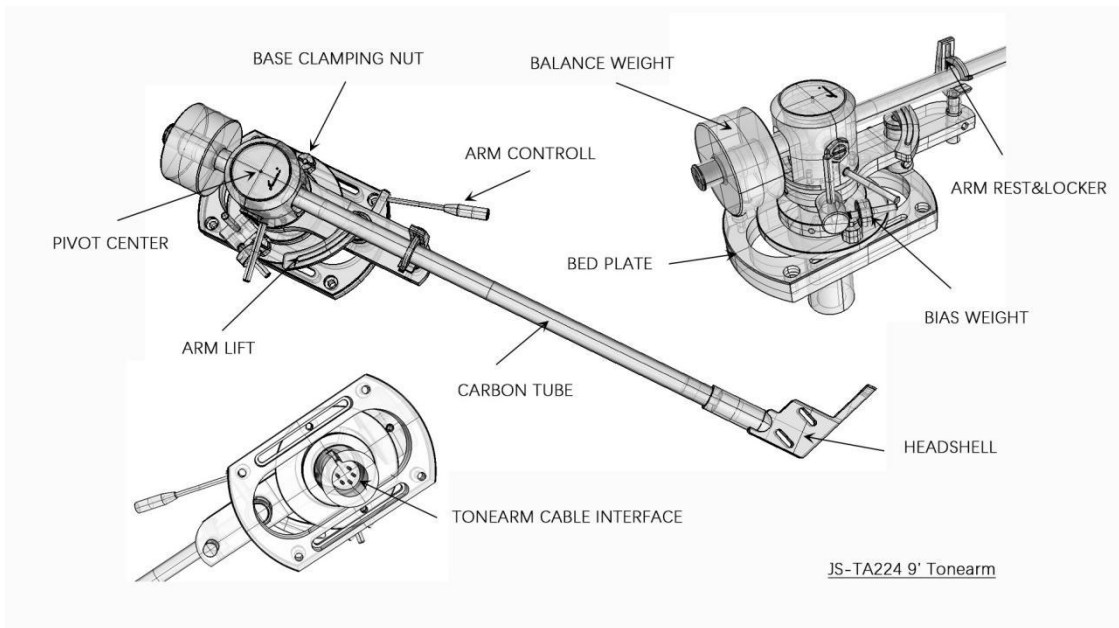

Arm base installation

The mounting distance of JS-TA224 is 224mm. Please make sure that the tonearm can be installed on your turntable before installation.

1. Open holes for arm base

Please open holes for JS-TA224 arm base at the 224mm mounting distance according to the size in the figure below, and install the arm base equipped with the arm.

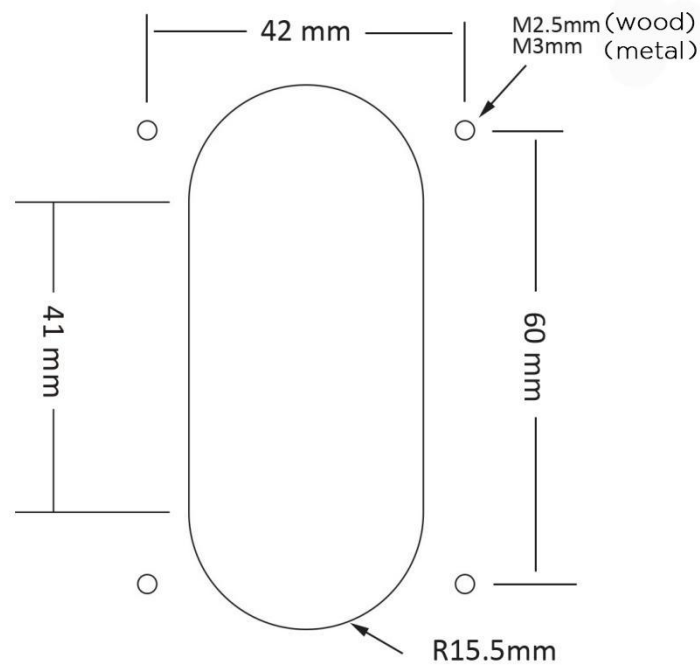

2. Setting mounting distance and VTA

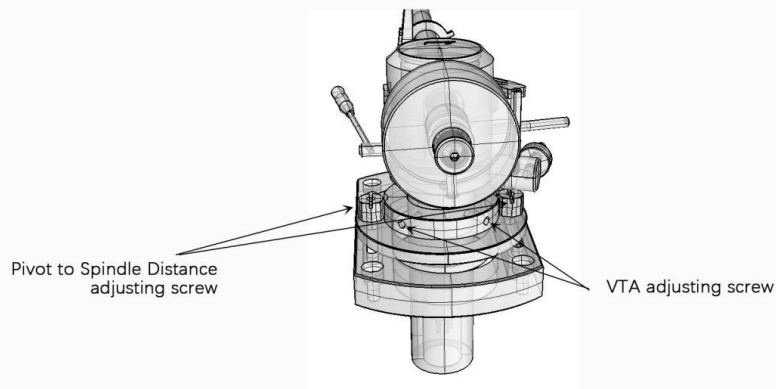

FIGURE. 2

Tonearm cable connection



Please refer to the following picture to insert the arm cable connector in place !



Install a cartridge

JS-TA224 tonearm is specially equipped with a protractor to set the cartridge. As shown as the figure below:

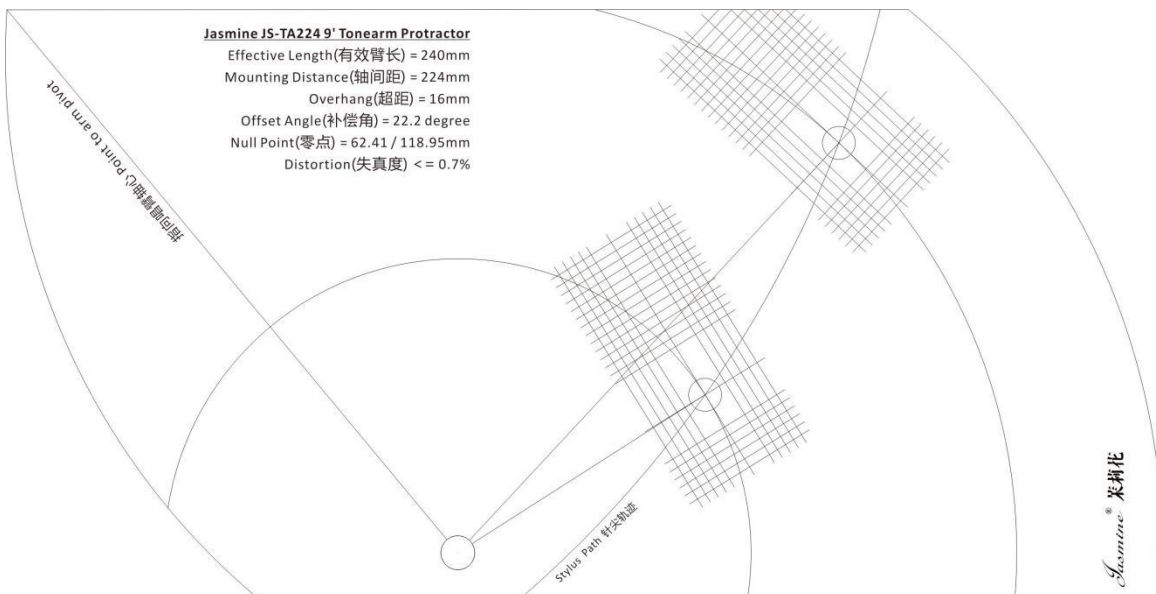

Step 1: first, put the protractor into the central pillar of the turntable, and rotate the protractor until the line "pointing to the arm pivot" is aligned with the arm pivot center.

Step 2: install the cartridge and connect the four cartridge cords according to the corresponding color. Red and green are the right channel, white and blue are the left. Then install the cartridge on the headshell of the tonearm. Before adjusting the azimuth angle of the cartridge, be sure to set the tracking force to about 1.5g, so as to prevent the stylus from being damaged due to excessive pressure.

Step 3: move the cartridge back and forth until the tip of the stylus moves precisely along the "stylus Path" from the outside to the inside.

Step 4: adjust the horizontal and vertical azimuth angles of the cartridge so that the bottom edge of the cartridge is parallel to the protractor surface, and the two sides are parallel to the vertical line of the null point matrix.

Step 5: VTA adjustment. Upper or lower the height of the tonearm pillar to make the tonearm tube parallel to the protractor surface.

Step 6: Calibrate the stylus tracking force again according to the specification of the cartridge !

JS-TA224 SPECIFICATION:

Effective length (有效臂长) :	240mm
Pivot to Spindle distance (轴间距) :	224mm
Overhang (超距) :	16mm
Offset angle (补偿角) :	22.2 °
Peak Distortion (最大失真度) :	<= 0.7%
Null points (零点) :	62.41mm/118.95mm
Cartridge weight (适应唱头重量) :	min. 5, max. 17 g
Effective mass (有效质量) :	7 g
Total weight (唱臂总重) :	238 g
Packing Size (包装尺寸) :	460*176*176mm
Packing Weight (包装重量) :	1.0 Kg

Copyright@Jasmine Audio, 2020
Subject to change without notice.

Warranty Card

- Thank you and congratulations on your purchase from Jasmine Audio
- We will confirm your purchase certificate and provide warranty service according to the warranty terms. Please keep this warranty card properly.
- Please show the warranty card when applying for maintenance service.
- Please contact the distributor of the product you purchased to ensure that you can get technical support and service in time.

Contact information of warranty:

email: aftersales@jasmineaudio.net

<http://www.jasmineaudio.net>

MODEL : _____

SERIAL No. : _____

DATE : _____